

REVISION HISTORY			
REV.	DESCRIPTION	DATE	APPROVED
03	REFER TO REVISION CONTROL LIST	18 DEC 07	WLW

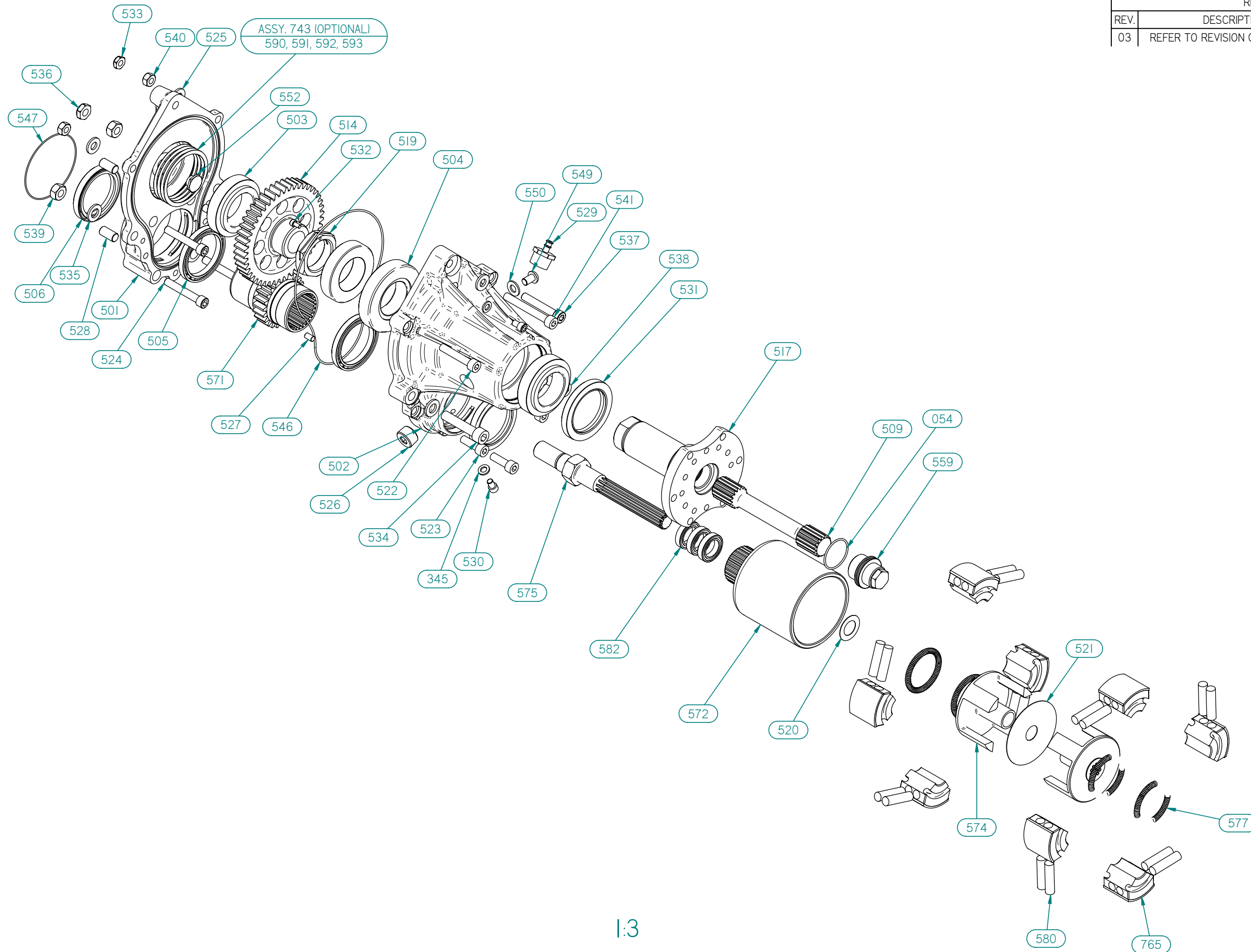

1:3

<small>PROPRIETARY AND CONFIDENTIAL</small> <small>THE INFORMATION CONTAINED IN THIS DRAWING IS THE SOLE PROPERTY OF AEROTWIN MOTORS CORPORATION. ANY REPRODUCTION IN PART OR AS A WHOLE WITHOUT THE EXPRESS PERMISSION OF AEROTWIN MOTORS CORPORATION IS PROHIBITED.</small>			<small>UNLESS OTHERWISE SPECIFIED:</small> <small>INTERPRET GEOMETRIC TOLERANCING TO ANSI Y 14.5 1994</small> <small>DIMENSIONS ARE IN mm</small> <small>GENERAL TOLERANCES:</small> <small>1 DEC. PLACES = +0.5</small> <small>2 DEC. PLACES = +0.25</small> <small>3 DEC. PLACES = +0.10</small> <small>ANGULAR = +0.3°</small> <small>BREAK EDGES 0.3</small> <small>CORNER RADII 0.3</small> <small>MACHINE FINISH 125µm/3.2µm Ra</small> <small>DO NOT SCALE DRAWING</small>	<table border="1"> <tr> <th>NAME</th> <th>DATE</th> </tr> <tr> <td>DRAWN DCB</td> <td>3/26/2007</td> </tr> <tr> <td>CHECKED WLW</td> <td>3/26/2007</td> </tr> <tr> <td>ENG. APPR.</td> <td></td> </tr> <tr> <td>MFG. APPR.</td> <td></td> </tr> <tr> <td>QA</td> <td></td> </tr> </table>	NAME	DATE	DRAWN DCB	3/26/2007	CHECKED WLW	3/26/2007	ENG. APPR.		MFG. APPR.		QA		DRAWING NO. 781
	NAME	DATE															
DRAWN DCB	3/26/2007																
CHECKED WLW	3/26/2007																
ENG. APPR.																	
MFG. APPR.																	
QA																	
<table border="1"> <tr> <td>NEXT ASSY.</td> <td>USED ON</td> </tr> <tr> <td colspan="2">APPLICATION</td> </tr> </table>	NEXT ASSY.	USED ON	APPLICATION				<table border="1"> <tr> <td colspan="2">COMMENTS:</td> </tr> </table>	COMMENTS:		<table border="1"> <tr> <td>TITLE:</td> <td>REV.</td> </tr> <tr> <td>781, Gear box 1 to 2 ratio and clutch exploded</td> <td>03</td> </tr> </table>	TITLE:	REV.	781, Gear box 1 to 2 ratio and clutch exploded	03			
NEXT ASSY.	USED ON																
APPLICATION																	
COMMENTS:																	
TITLE:	REV.																
781, Gear box 1 to 2 ratio and clutch exploded	03																
		<table border="1"> <tr> <td>SIZE</td> <td>MATERIAL: REFER TO PART DRAWINGS</td> </tr> <tr> <td>A2</td> <td>CONDITION REFER TO PART DRAWINGS</td> </tr> </table>	SIZE	MATERIAL: REFER TO PART DRAWINGS	A2	CONDITION REFER TO PART DRAWINGS	<table border="1"> <tr> <td>SCALE: SHOWN</td> <td>WEIGHT: SHOWN</td> <td>SHEET 1 OF 2</td> </tr> </table>	SCALE: SHOWN	WEIGHT: SHOWN	SHEET 1 OF 2							
SIZE	MATERIAL: REFER TO PART DRAWINGS																
A2	CONDITION REFER TO PART DRAWINGS																
SCALE: SHOWN	WEIGHT: SHOWN	SHEET 1 OF 2															

